

ISO-FSN-HF

Two way plug valve with safety stuffingbox packing, special design for HF alkylation, Monel materials

Type ISO-FS-HF with Fire Safe sealing

Type ISO FSN-HF with triple safety sealing for fluctuating temperatures

ASME: NPS ½" - 8" / class 150 / 300

PT range: $-30 < T < 230/280^{\circ}\text{C}$, vacuum 10-8 mbar

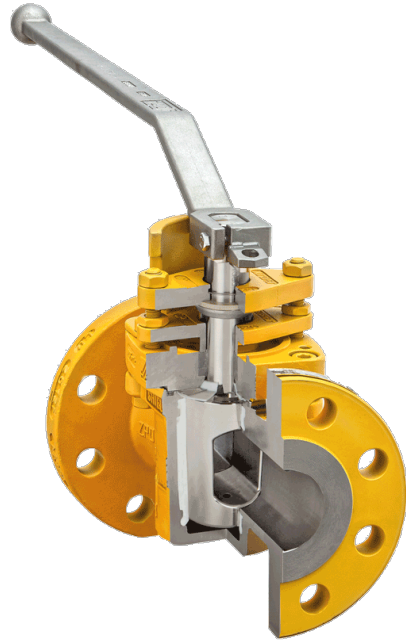

Design Features

Design Characteristics

- free of cavities
- maintenance free - self lubricating
- easy accessible adjustment of the plug, even with mounted actuator
- vacuum tight
- fugitive emission resp. clean air act certified (TA - Luft 2002 approval)
- Directive 2014/68/EU
- fire safe design API 607 / ISO 10497
- special design for hydrofluoric acid (HF alkylation):
 - monel body, plug and cover
 - Flanges and cover seat painted with special acid detection paint (yellow or orange)
 - plug with relief hole
 - Cover sealing with stuffingbox packing type "FSN"
 - X-ray examination on critical areas

PT-Diagram

General Pressure-Temperature-Diagram

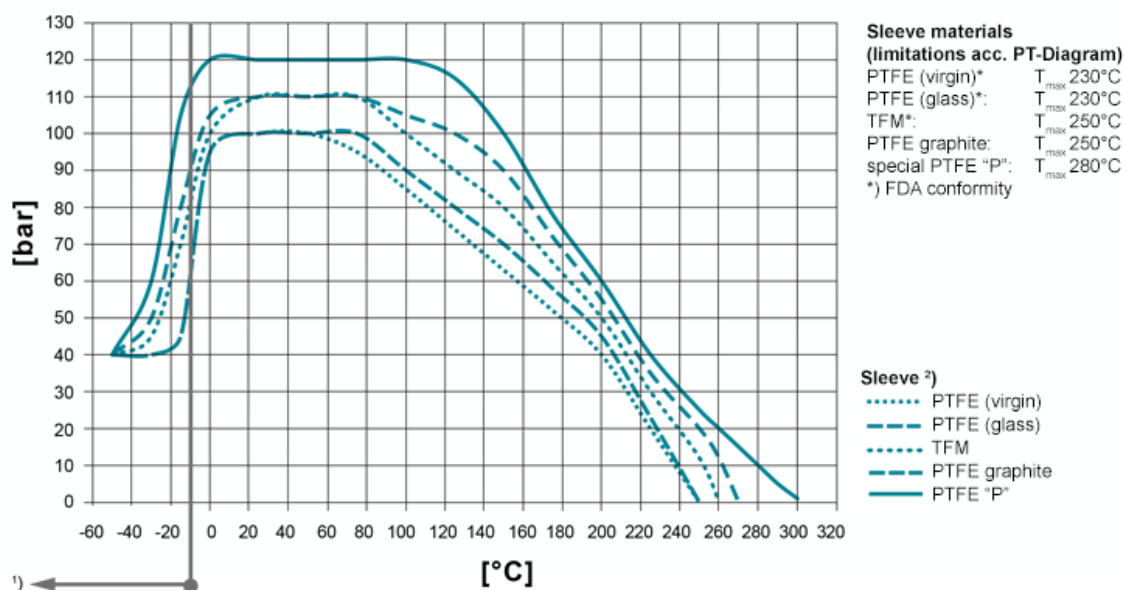

Operating temperatures < -30°C and > 220 °C have to be checked and approved by AZ according to the operating conditions.

Besides the P/T value of the sleeve the limitations of the valve bodies also have to be considered. Please refer to the EN 12516-1 resp. ASME B16.34 in order to choose a proper pressure rating (PN/class). The shown values refer to austenitic stainless steel 1.4408 (A351 Gr. CF8M).

- 1) For operating temperatures below -10°C low temperature / austenitic steels are required.
- 2) Sleeve: There are different sleeve materials / compounds available.

Materials

Standard body material

- Monel, ASTM A494 M35.1

Standard plug material

- Monel, ASTM A494 M35.1

Sealing Systems

**Firesafe safety sealing (API 607) for fluctuating temperatures
with 3x graphite packing (adjustable) for additional
stem sealing; Tmax 280°C**

Type FSN

read more [...]

Firesafe sealing (API 607) with graphite packing for additional stem sealing; Tmax 220°C

Typ FS-HF

read more [...]

Plug Forms

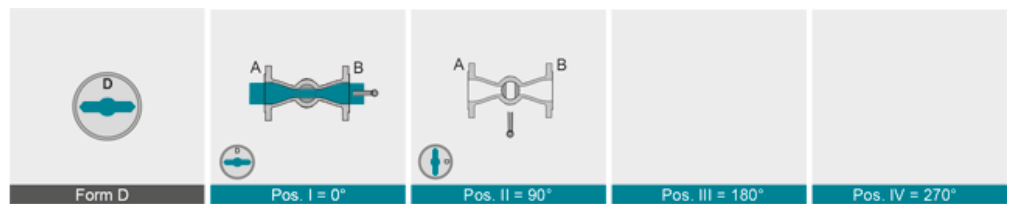

Dimensions

AZ-ISO-bracket
for actuator

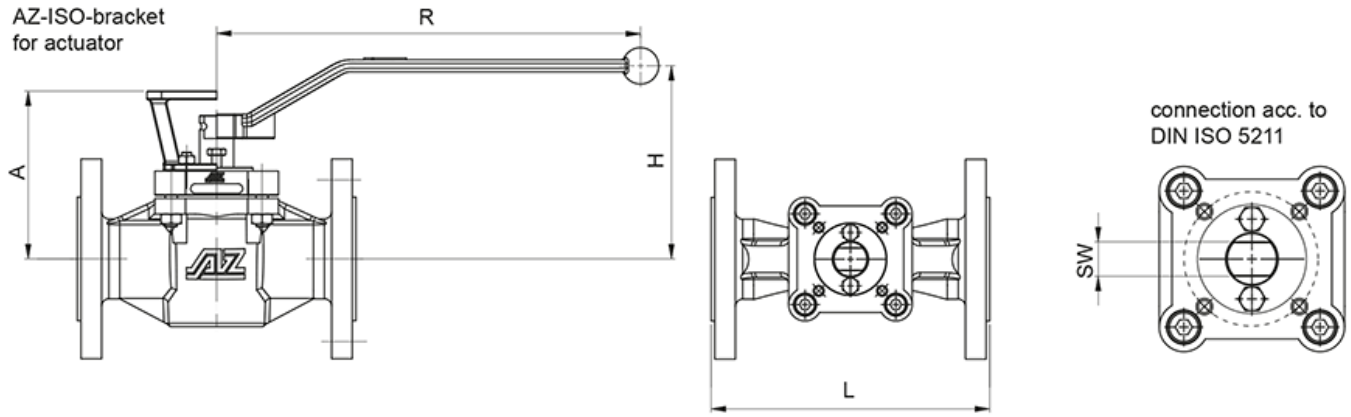

DIN EN 1092-1 / 558-1

ASME B 16.5 / 16.10

DN	PN	L	øD	bracket / lever			DIN flange	dihe-dron	torque* [Nm]	weight [kg]	K _{vs} -value [m³/h]	C _v -value [US.gal/min]
				A	H	R						
15	10-40	130	95	88	103	200	F05	11	30	3,8	12	14
20	10-40	150	105	88	103	200	F05	11	30	4,3	13	15
25	10-40	160	115	94	109	200	F05	11	30	4,9	25	29
32	10-40	180	140	102	117	320	F07	14	70	8,6	46	53
40	10-40	200	150	109	124	320	F07	14	80	9,6	85	98
50	10-40	230	165	139	159	420	F07	19	120	13,9	160	185
65	10-16 25-40	290	185	158	165	600	F10	22	200	19,3	262	302
80	10-40	310	200	158	165	600	F10	22	200	21,4	275	317
80S	10-40	310	200	173	180	600	F12	22	300	24,6	417	482
100	10-16 25-40	350	220 235	158	165	600	F10	22	200	24,6	197	228
100S	10-16 25-40	350	220 235	173	180	600	F12	22	300	28,9	582	673
NPS	class	L	øD	bracket / lever			DIN flange	dihe-dron	torque* [Nm]	weight [kg]	K _{vs} -value [m³/h]	C _v -value [US.gal/min]
				A	H	R						
½"	150	108	90	88	103	200	F05	11	30	2,7	14	16
	300	140	95							3,8	13	15
¾"	150	117	100	88	103	200	F05	11	30	3,2	13	16
	300	152	115							4,3	13	15
1"	150	127	110	94	109	200	F05	11	30	3,5	24	28
	300	165	125							4,9	26	31
1¼"	150	140	115	102	117	320	F07	14	70	5,4	46	53
	300	178	135							8,6		
1½"	150	165	125	109	124	320	F07	14	80	7	78	90
	300	190	155							9,6	79	92
2"	150	178	150	139	159	420	F07	19	120	11,8	145	167
	300	216	165							13,9	156	180
2½"	150	190	180	158	165	600	F10	22	200	15,5	236	273
	300	241	190							19,3		
3"	150	203	190	158	165	600	F10	22	200	18,2	225	260
	300	282	210							21,4	228	264
4"	150	229	230	158	165	600	F10	22	200	20,3	169	195
	300	305	255							24,6	198	229
4"S	150	229	230	173	180	600	F12	22	300	24,6	523	604
	300	305	255							28,9	542	627

* inclusive 100% safety factor for actuators

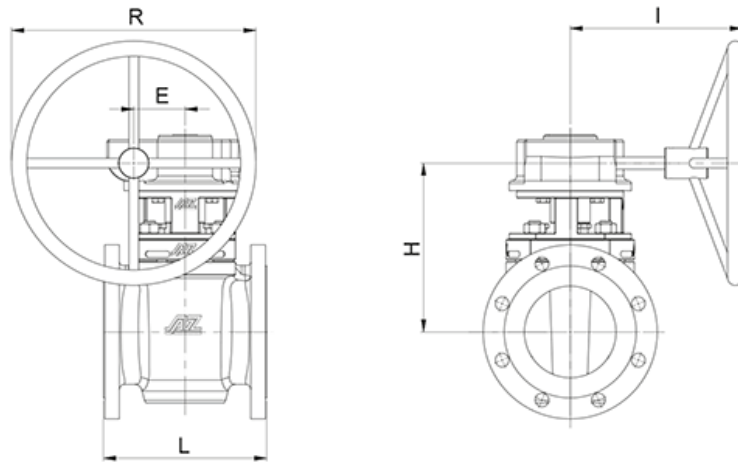

DIN EN 1092-1 / 588-1

ASME B 16.5 / 16.10

DN	PN	L	E	gear (Pro-Gear)			Typ	DIN flange	dihe-dron	torque* [Nm]	weight [kg]	K _{v5} -value [m³/h]	C _v -value [US.gal/min]
				R	H	I							
125	10-16	325	84	400	277	290	Q1500-S	F16	36	900	67	865	1000
	25-40										71		
150	10-16	350	84	400	277	290	Q1500-S	F16	36	900	77	875	1011
	25-40										79		
200	10-16	400	96,5	600	320	350	Q3000-S	F16	36	1200	108	1770	2047
	25 40										119		
250	10 16	450	117,5	600	328	465	Q5000-S	F16	36	1500	177	2788	3223
	25 40										235		
300	10 16	500	117,5	600	366	465	Q5000-S	F16	36	2600	230	2618	3027
	25 40										249		
350	10 16	550	137,5	600	460	465	Q6500-S	F25	46	5500	395	5070	5861
	25 40										468		
400	10 16	600	137,5	600	460	465	Q6500-S	F25	46	5500	411	4694	5426
	25 40										525		
450	10 16	650	180	600	485	520	Q12000-S	F30	55	6400	611	8065	9323
	25 40										730		
500	10 16	700	180	600	510	520	Q12000-S	F30	55	7500	655	10260	11862
	25 40										744		
600	10 16	800	180	600	510	520	Q12000-S	F30	55	7500	681	7980	9226
	25 40										863		
NPS	class	L	E	gear (Pro-Gear)			Typ	DIN flange	dihe-dron	torque* [Nm]	weight [kg]	K _{v5} -value [m³/h]	C _v -value [US.gal/min]
				R	H	I							
5"	150	254	84	400	277	290	Q1500-S	F16	27	900	55	738	853
	300	325									71		
6"	150	267	84	400	277	290	Q1500-S	F16	27	900	60	775	896
	300	403									70		
8"	150	292	96,5	600	320	350	Q3000-S	F16	36	1200	94	1517	1754
	300	419									125		
10"	150	330	117,5	600	328	465	Q5000-S	F16	36	1500	127	2239	2589
	300	457									160		
12"	150	356	117,5	600	366	465	Q5000-S	F16	36	2600	153	1904	2202
	300	502									170		
14"	150	686	137,5	600	460	465	Q6500-S	F25	46	5500	180	2448	2830
	300	762									210		
16"	150	600	137,5	600	460	465	Q6500-S	F25	46	5500	246	5131	5932
	300	600									305		
18"	150	864	180	600	485	520	Q12000-S	F30	55	6400	627	9135	10561
	300	914									763		
20"	150	914	180	600	510	520	Q12000-S	F30	55	7500	698	11728	13559
	300	991									860		
24"	150	1067	180	600	510	520	Q12000-S	F30	55	7500	825	9863	11402
	300	1143									1070		

* inclusive 100% safety factor for actuators

For geometric reasons, threads are used in the flange bores in a few cases

Actuation

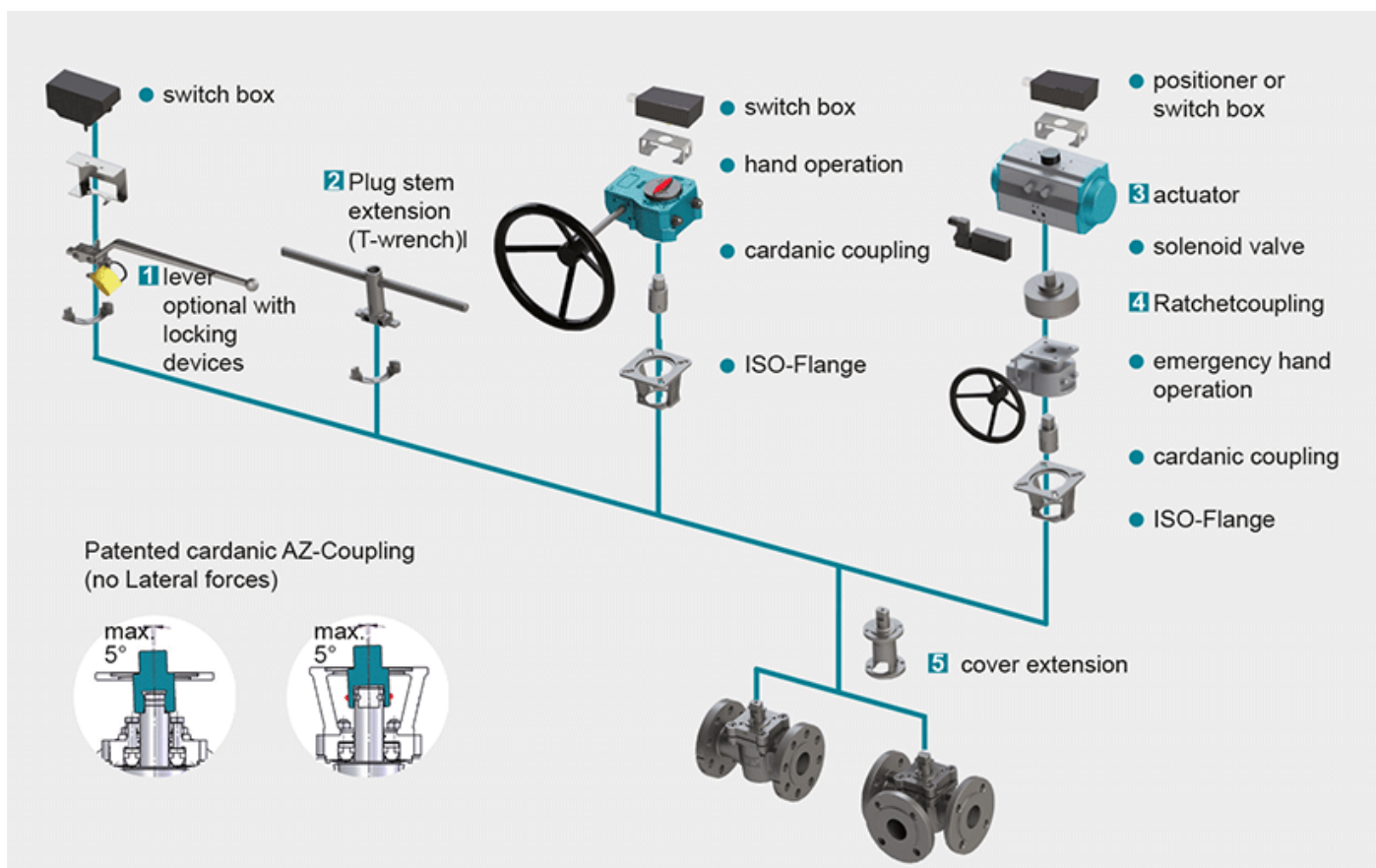

1 Locking Devices

Pilot valve combinations, pad lock eyelets, linear key conception, indexing plunger arrestor.
read more [...]

2 Plug stem extension

Solid construction in stainless steel with T-wrench, Standard extension 100 mm or 150 mm, non standard lengths are available on request
read more [...]

3 Actuators

Actuators for mounting-flange acc. to DIN ISO 5211
read more [...]

NEW: Pneumatic actuator AIR GEAR for plug valves with high torque ≥ 150.000 Nm
read more [...]

4 Ratched coupling

To usw on multiport valves with standard 90° actuator for bigger switchpositions than 90°
read more [...]

5 Cover extension

Solid construction in stainless steel, Standard extension 100 mm or 150 mm high, non standard lengths are available on request . Hexagonal bolts on adjustment ring freely accessible. Note: Don't use with sealing

FSN/FSN-SL and CASN/CASN-SL
read more [...]